

Smith-Corona

Congratulations

YOU NOW OWN
THE WORLD'S FINEST
PORTABLE TYPEWRITER



Smith-Corona

We feel sure you will enjoy your new Smith-Corona portable typewriter and that the information this booklet contains will assist you in getting the complete satisfaction from it that thousands of other users enjoy.

Your individual Smith-Corona may be most positively identified by the serial number. The location of the serial number is pointed out in Fig. 14. Make a record of this number some place where you can find it in case of theft. Learn to use it in ordering ribbons, accessories and other typing supplies.

**Smith-Corona
Inc**

Should your Smith-Corona need mechanical attention or when it requires cleaning, oiling and a tune-up you will most likely return it to the dealer from whom purchase was made.

We have a most complete service coverage throughout the United States.

If you change address or are traveling with your Smith-Corona along we will be glad to furnish the location of our nearest authorized servicing representative. Should you be in immediate need just consult the local phone directory for Smith-Corona, under typewriters in the classified section.

**Smith-Corona
Inc
Syracuse, New York**

Replacing the Machine in the Carrying Case (Fig. 18)

This operation is extremely simple yet we have seen quite a few machines that were damaged because they had been improperly located on the machine case holding cleats.

Center the carriage—hanging onto the right hand platen knob with your fingers, hold up the centering lever with your thumb and allow the carriage to move to the left as far as the centering lever permits.

Pick up your Smith-Corona with both hands, front slightly higher than the rear. Now first, and this is where many go wrong, make very sure the two pronged cleat at the back of the case has really entered the double opening in the back of the machine. When the rear of the machine is positively on the rear holding cleat the front of the machine is almost bound to line-up with the front holding cleat. Just see that the front of the machine is way down and latched on the front cleat. It is well to form the habit of lifting up on the front of the machine, to make sure it is safely latched before closing the case. Perhaps you are wondering about the two case side supports. They do not require attention when putting the machine away. They will enter the openings in the bottom flange of the machine main frame when you have located your Smith-Corona on the rear case cleat and lowered the front onto the front case cleat.

It may be that you have removed the case lid. If so simply snap the latch hinges together again. These are something different in the way of hinges. If you will look them over you will readily see that when the case is closed the hinges just cannot come unlatched.

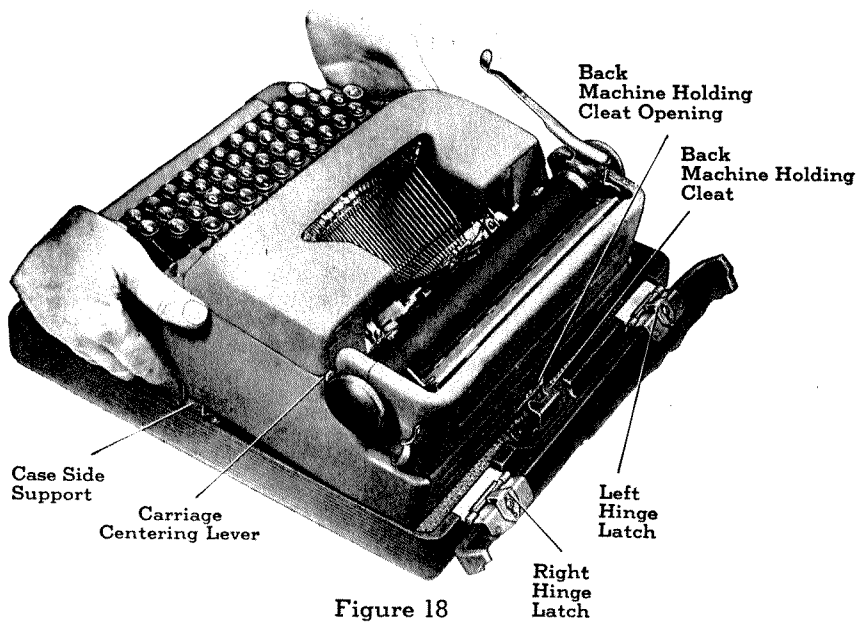

Figure 18

Removing Machine From Case (Fig. 1)

We don't expect you had any difficulty getting the case open. Probably you have already unfastened the key from the case handle.

Your Smith-Corona types best and most quietly when operated out of the case. Press down on the machine release lever, in the bottom of the case, lift the front of the machine up about two inches and then pull it forward and out. Done in a jiffy and no tools required yet the case cleats hold the typewriter securely for the rigors of travel. After a few trials it will become a habit to press the machine release lever with your left little finger, the other fingers under the machine as shown here, while reaching under the right hand side to lift the machine from the case in one smooth operation.

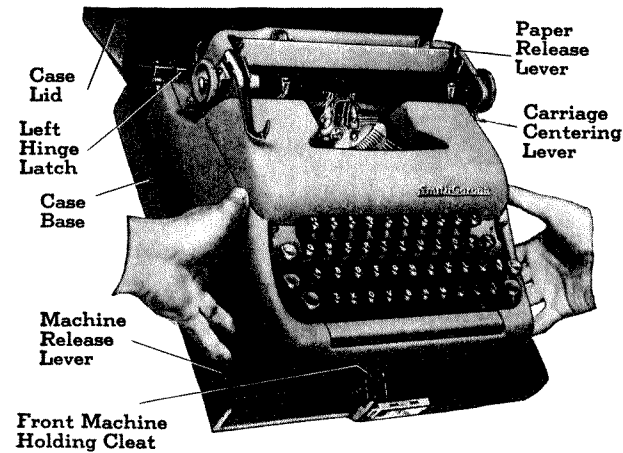

Figure 1

If you have no writing surface handy, like a table or desk, take off the case lid and hold the machine, in the case base, on your lap. It is surprising how well typing will thus progress with a Smith-Corona. To take off the lid, just push back both the right and left hand hinge latches and unhook the halves of both hinges. With your fingers around the lid your thumbs will reach the hinge latches on each side. Try it—another single, smooth operation.

Placing The Machine In Operation (Fig. 1)

Push the carriage an inch or two to the right. Click and you are ready to type. When you pushed the carriage, the carriage centering lever automatically released. Not only does this accessible little lever provide a means of quickly centering the carriage to fit the case, but by disengaging the letter spacing mechanism, protects it against injury when the machine is not in use.

Now snap the paper release lever up to writing position. Try to remember to always put your typewriter away with the paper release lever down in released position. Constant pressure on the paper feed rolls, when inactive, tends to flatten them.

This is Your Portable

There is a right way to do most things including Coronatyping. We would like to say, just throw a sheet into the machine and type away. But we don't think that would be fair to you. We know that in the long run you will get the full value from your Smith-Corona by knowing the why and wherefore of all the features and operational conveniences.

The Margin Retaining Guide (Fig. 2)

On the paper table of Smith-Corona Silent-Super, Silent and Sterling models you will find the margin retaining guide that is adjustable to the marginal scale (also on the paper table). This guide ensures uniform left margins on one page after another without resetting the margin stops for each sheet. Just put the left edge of the paper against this guide as the sheets are fed into the machine. Setting the guide at "0" or wherever set on the marginal scale brings the left edge of the paper opposite the same corresponding mark on the carriage front scale. The margin retaining guide is mighty handy too when you want to alter your usual left margin a little for only a page or two. For instance, suppose you want a slightly greater or smaller margin without the bother of disturbing your regular marginal set-up. Slide the guide a little to the left for margin increase or to the right to decrease—don't bother resetting the margin stops—then return to your regular set-up by sliding the guide back to the original position. The range of varying the margin retaining guide horizontal adjustment is limited only by the width of paper used. For example, paper $8\frac{1}{2}$ inches wide limits varying the guide horizontally, either way, to about $\frac{3}{8}$ inches.

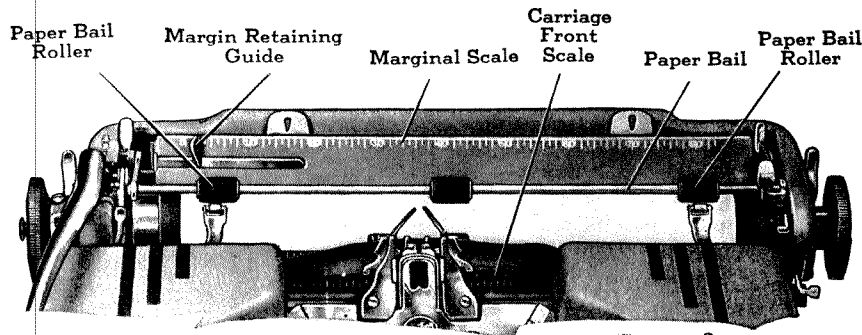

Figure 2

3 Position Paper Bail (Figs. 2 and 3)

Paper bails are regular equipment on Smith-Corona Silent-Super, Silent and Sterling portables but not on the Clipper. Bails for the Silent-Super and Silent models have three adjustable rollers while on the Sterling there are two.

Slide the end rollers so that they locate about a half inch inside the edges of the paper. The center roller, on Silent-Super and Silent models, should be centered on the paper. So locating the rolls for equalized contact on the paper, promotes straight paper feeding as typing progresses.

During paper insertion pull the bail forward. There is a finger piece at the right end. It is possible to type with the bail forward but you will get better results by pushing it back against the paper where it will smooth it out and hold it against the platen for sharper type impressions while at the same time considerably reducing type impact noise.

Your Smith-Corona bail can be swung upward and back (see Fig. 13) completely out of the way for erasing—we all have to occasionally—and for platen interchanging in our Silent-Super and Silent models.

Speaking of erasing: try to form the habit of moving the carriage to the extreme end so erasings will drop OUT OF not INTO the machine.

The last step is to thread the ribbon through the vibrator, some times called the ribbon carrier. Follow this simple procedure.

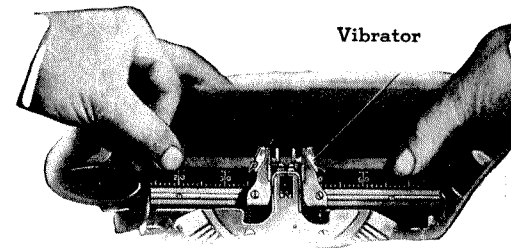

Figure 15

A. Place the ribbon behind the vibrator like this;

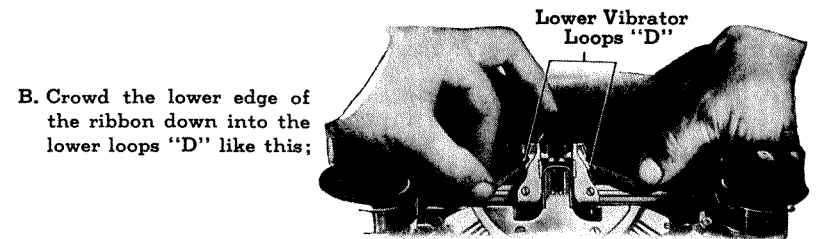

Figure 16

B. Crowd the lower edge of the ribbon down into the lower loops "D" like this;

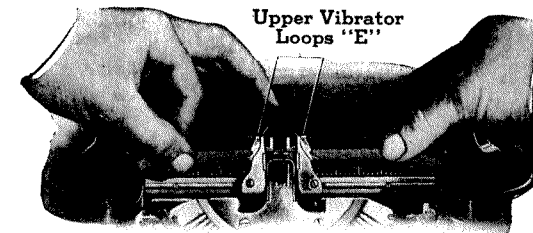

Figure 17

C. Now straighten out the ribbon so the upper edge passes up into the upper loops "E" like this;

D. Pull the ribbon a little to the right and left to see that it is properly located on the spools, through the spool cup openings and reverse actuators and is threaded through the vibrator as it should be without wrinkles or creases. Take up any slack in the ribbon by turning the left spool counter-clockwise or the right spool clockwise.

Close the cover plate making sure it is held down by the latch shown in Fig. 14.

Unwind about two inches of the new ribbon and put spool on the right hand spindle—red down and so the ribbon unwinds from the **BACK** of the spool.

The top of the spool should go down almost flush with the edge of the spool cup as in Fig. 14. If it doesn't, turn it counter-clockwise as you press it gently into place. If the spindle turns with the spool, push down the manual ribbon reverse lever, shown in Fig. 14.

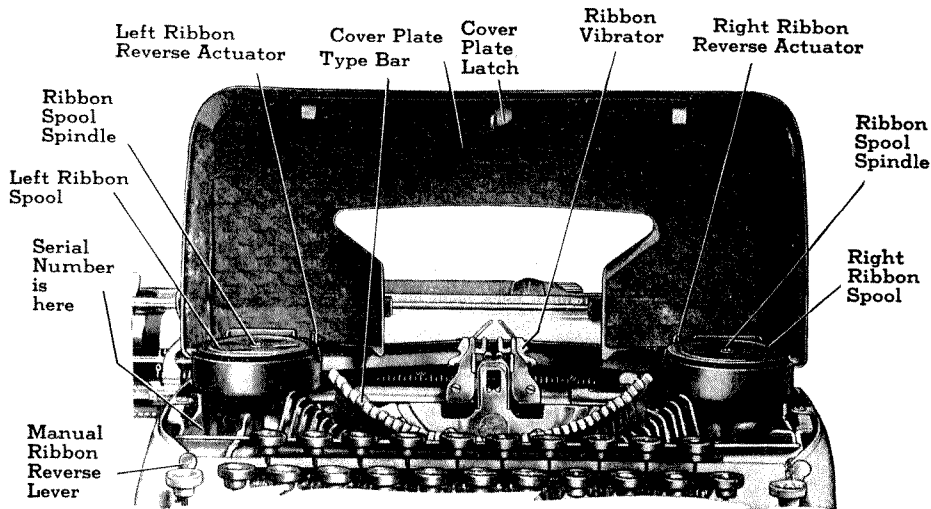

Figure 14

Attach loose end of new ribbon to empty spool by holding against the spear in the spool hub and pulling on the ribbon until the spear pierces it about 1/2 inch from the end. For the left side, have spear pointing to the left when it pierces the ribbon.

Wind the ribbon on the empty spool until the eyelet in the ribbon is covered. Put spool on the left spindle making sure it goes way down by turning clockwise. If spindle turns with the spool, manipulate the manual reverse lever to prevent it.

The ribbon should wind to and from the **BACK** of each spool like this.



Next, drop the ribbon into the slots of the reverse actuators.

Slip the ribbon into the slot of each reverse actuator (See Fig. 14). Some actuators are slotted from the top and others from the back.

Be sure the metal eyelets, one near each end of the ribbon, are between the actuators and the ribbon spools and that the ribbon passes through the side opening in each spool cup.

Lock the shift in capital letter position.

Suggestion: when you erase if you don't have an erasing shield, turn the paper back so that the top of the line in which erasing is to be done is just beneath the bail shaft. You may need to move the center bail roll on the shaft temporarily. In this way the bail shaft provides a good straight edge for the erasure and at the same time protects the line above.

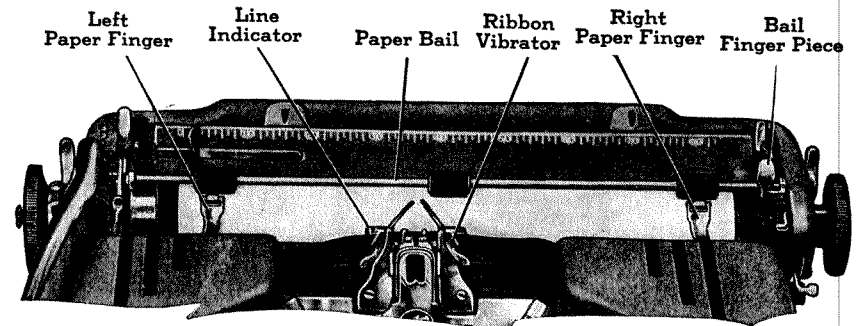

Figure 3

Paper Fingers (Fig. 3)

These are regular equipment on the Silent-Super, Silent, and Clipper, but are not included on the Sterling model.

Slide the paper fingers so they will locate about a half inch from the edges of the paper. It is best that the paper fingers be located on the outside of the marginal stops. In other words, if they are located on the paper beyond the ends of the typed lines they cannot interfere with the line indicator or ribbon vibrator.

Inserting Paper (Fig. 4)

Hold the paper square, drop it down onto the feed rolls behind the platen roller and twirl either platen knob clockwise. Upon dropping the paper in

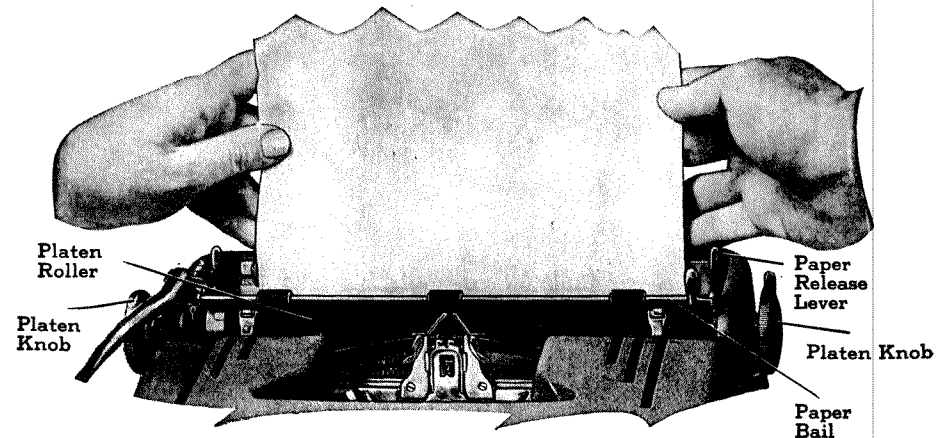

Figure 4

squarely the accurate paper feed will usually carry it through without help and bring it up straight in front. However, it is no bother to assist feeding with a little hand pressure especially heavy loads like kraft envelopes and multiple copies. Even though seldom used you will find a paper release lever over at the right end of the carriage. When pulled forward it frees the paper for straightening. Be sure to snap the paper release back up to normal when you are ready. Notice that when the paper release lever is forward it not only relieves paper feed roll pressure but also relieves paper bail roll pressure. Sometimes it is advantageous to pull the paper release forward when putting in a really heavy book of many carbons.

About this matter of heavy loads: a trick to assist feeding a book of carbons so the edges of all copies come up even is to fold a narrow piece of paper, about as long as your sheets are wide, place it over the top edge of the sheets then turn the load in far enough so this improvised guide can be removed. After this, if necessary, turn the paper back to where you want typing to begin.

Carriage Releases (Fig. 5)

There are times, for instance to gage margins or tabulation set-up, when you will want to move the carriage to the right or left without the nuisance of spacing a notch at a time. For convenience there is a carriage release lever at either end of the carriage. To move the carriage to the right simply push it over. To move to the left hold either the left or right hand carriage release lever forward.

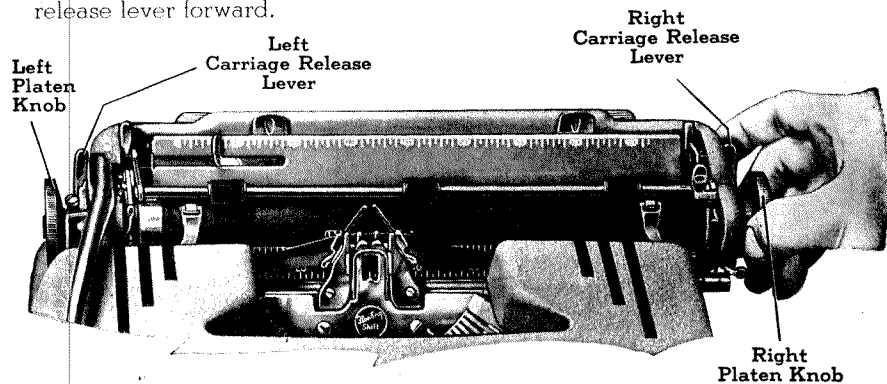

Figure 5

It is a good plan to hook your thumb over the platen knob to control the carriage. This is not a two handed operation. Use your finger on the carriage release and your thumb on the platen knob as demonstrated here. This is especially true when releasing from the right end as the extremely responsive carriage action might let the carriage get away from you.

Instant Marginal Control (Fig. 6)

The ease of setting the stops for uniform, businesslike side margins is indeed a pleasure on the Smith-Corona.

All you do is estimate, on the front scale, what margins you want. Suppose you decide on "15" for the left and say "70" for the right. Press down

Interchangeable Platen (Fig. 13)

Smith-Corona Silent-Super and the Silent models come so equipped; not the Sterling or the Clipper.

We are proud to say that the interchangeable platen is a Smith-Corona exclusive feature in the portable field.

Your Smith-Corona Silent-Super and Silent is equipped with a full cushioned, quieting platen roll yet for heavy manifolding work or for cutting stencils this full cushioned roll may be changed in a jiffy to a harder, manifolding platen or one better adapted to stencil work. The full cushioned regular roll, however, lends itself very well to the making of 4 carbon copies which is usually more than enough for run of the mill typing. That is, if proper carbon paper is used.

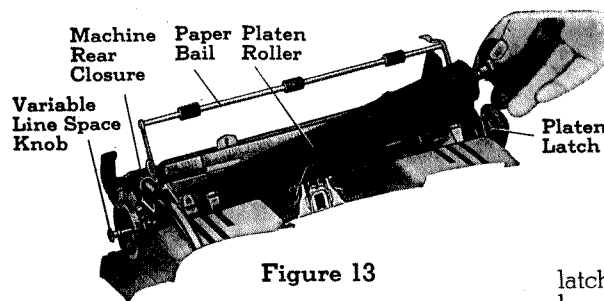

Figure 13

To take out the platen, push the top edge of the machine rear closure back until it swings down to open position. Next swing the paper bail up to fully raised position. Pull out the variable line-spacing knob to "variable", hold up on the platen

latch and lift out the roll, right hand end first. We suggest you

hold up the platen latch with your left thumb, getting leverage with left fingers braced against machine cover. It is just as easy to replace the platen. Put it back left end first while slowly turning it. See that it is seated way down in the right hand carriage end so that the platen latch automatically snaps into place to securely lock the platen in position. A platen that is so quickly and easily taken out and put back makes it easy for you to keep your machine clean and in good shape. Slip out the platen, brush the dirt and erasings from underneath and then wipe off the paper feed rolls and platen with alcohol and slip the roller back into position. By doing this periodically you will keep the paper feeding efficiently and your platen will be in shape for the best of typing.

How to Replace the Ribbon

Ribbons come wound on proper spools. To get the correct replacement ribbon and spool for your Smith-Corona, identify your machine by serial number. Serial location is shown in Fig. 14.

MOVE THE CARRIAGE TO THE EXTREME LEFT. Swing the cover plate up to raised position as in Fig. 14. The easiest way to do this is by catching your fingers under the edge of the cover plate just above the type.

Tear the old ribbon in two and lift off both spools. Save one of the old spools for use on the left. The new ribbon is wound on a spool ready for use on the right hand side. The cleanest way to remove old ribbon from the spool to be saved is to stick a small rod, like a straightened out paper clip, through the spool and spin it over a waste basket so the old ribbon falls in the basket.

With the Smith-Corona Super Key Set every bit of the tabulating process is done from the keyboard. No reaching or stretching. You set desired tab stops—clear individual stops one at a time or clear the complete tabulating arrangement previously established as well as tabulate, all from the keyboard and with the same hand.

The Manual Set Tabulator (Fig. 12)

The Smith-Corona Silent and Sterling models are equipped with a manual set tabulating mechanism. The Clipper model has no tabulator while the Silent-Super Model has a Key Set Tabulator. The tabulator has many uses in addition to typing figurative copy such as figures. Use it for quickly indenting paragraphs; for the dating of your correspondence or for instantly locating the letter closing position.

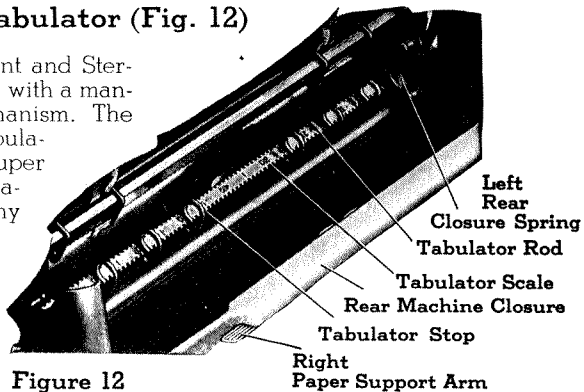

Figure 12

From the front scale determine where you wish the carriage to stop for each column or indentation. Now open the hinged, rear machine closure by pushing back on one of the paper support arms. There is the tabulator rod with a scale stamped in the top surface to correspond with the carriage front scale. There are 6 movable tabulator stops. When the rear machine closure is down we are sure you will appreciate how wide open the back of the carriage is for complete accessibility in setting up your tabulator stops. Notice also the unusual springing of the rear machine closure. They hold the closure down in open position so you need give it no attention while setting the stops yet they hold the closure snugly in the raised position so it will not rattle.

When listing figures containing decimals, set the stops where the decimal points are to come. Back space to start typing on proper digit. This method neatly lines up all the decimal points. If tabulating in a columnar ruled form, insert the form and set the stops accordingly.

Pull up on the tabulator stops to remove and reset them to the selected spaces. Push them back down in the selected slots of the tabulator rod. Be sure they are way down and slanting away from the machine.

If you are setting up only part of the 6 tabulator stops, say 3 for paragraphs; date and letter closing, set the other 3 in rod slots to the left or right of the first or last stops set-up. In this way these 3 unused stops not set-up will not interfere with the desired tabulating and yet will be where you can find them when you need them. Now flip the rear machine closure back up to "closed" position.

Smith-Corona tabulator is a marvel of easy action and absolute accuracy. When the tab stops are set where you want them you are sure you are going to stop on those spaces every single time the tabulator key is depressed.

the feather-touch marginal stops and slip the left one over to "15" and the right one over to "70" on the full length, completely visible marginal scale. The stops are then positively set without any guess work because when the red arrow on the stops point to certain spaces on the marginal scale, you know that is where the line of writing is going to begin and end every time.

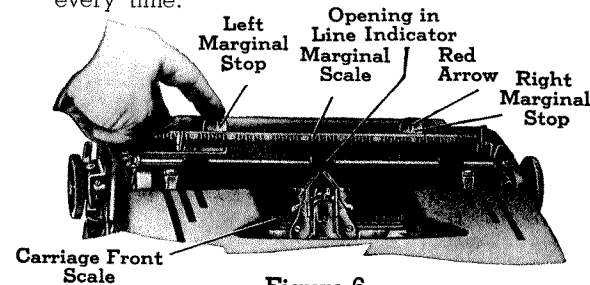

Figure 6

Another way to set your marginal stops is to move the carriage over to the right where you want the left margin and slide the left stop to the right as far as it will go. Just leave it there—pay no attention to either the marginal scale or front scale. Now move the carriage to the left

to where you want the right margin and slide the right stop over.

How can you tell where the printing is going to start and end? The type strikes directly under the little opening in the extreme top of the line indicator.

The primary purpose of the marginal scale is for setting margins but it also makes a mighty handy gage for locating the small labels or cards you will occasionally use. The marginal scale is absolutely synchronized with the front scale so, wherever edges of paper or cards are placed on the marginal scale that is where they are going to come opposite the front scale.

Marginal Releases (Fig. 7)

There are times when you will want to write into the margins—possibly to finish a word at the right or make a marginal note at the left.

A touch on the margin release key, so ready-at-hand in the keyboard, and you keep right on typing as far as you like to the extreme end of the line.

The handiest way to go into the left margin is to hold down the margin release key while you take one stroke on the backspace key. This is one of the reasons for the margin release and backspace keys being on opposite sides of the keyboard.

After one stroke on the backspacer you can let up on the margin release and still move into the left margin. Notice how easily the backspacer operates. It hardly seems possible that the whole carriage unit backs up with each backspace key stroke.

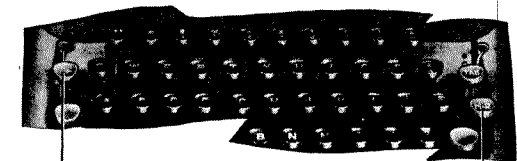

Back Space Key

Figure 7

Margin Release Key

Bell and Dual-Line Lock

A bell rings a few spaces before reaching the end of the line for which you have set the right margin stop. The bell will always ring the same num-

Touch Selector (Fig. 9)

With the cover plate raised you will want to become familiar with the touch selector lever. Shut your eyes, tap a key rhythmically and at the same time move the touch selector slowly to the left from L (low) to H (high). See how responsive it is and how noticeably the key stroke stiffens as the selector is moved over to the left. Smith-Corona touch selector instead of simply stretching the key springs, changes the position of the universal bar spring pick-up without altering the total spring tension to "load" the key stroke.

There is an ideal touch for every typist and when you have found yours with the Smith-Corona touch selector you will probably not have to change it as the selector is hidden under the cover plate where no one is likely to tamper with it.

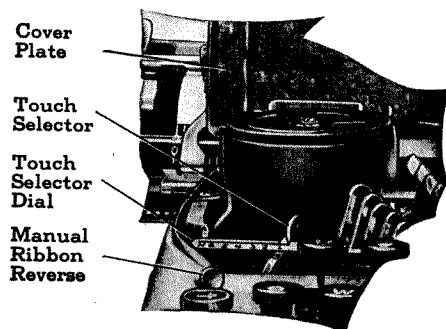

Figure 9

Linespacing (Fig. 10)

When you finish a line and are ready to start another, a smooth easy stroke on the good sized, comfortably shaped finger pad of the synchronized linespace-carriage return lever returns the carriage to the starting point and spaces the paper up for a new start.

Unlike some typewriters, Smith-Corona has all the important linespacing conveniences to facilitate your work. Notice that the linespace regulator is lined up with figures 1, 2 and 3. When the regulator is opposite 1 you will single linespace with each linespace-carriage return lever stroke. Set the regulator opposite 2 and you get double spacing and when at 3 you triple space. Right here let us consider an important point. The majority of typing is done in single linespacing. Why, therefore, should it be necessary to swing the linespacer the same long distance for 1 line as for 2 and 3 as most typewriters do? You don't on your Smith-Corona portable. When single spacing the lever travels only 1/2 as far as when double spacing and only 1/3 as far as when triple spacing. This is another time and effort saver of Smith-Corona engineering.

It is most natural to hit a linespace lever with a somewhat downward sweep, yet have no fear you will drive the linespace lever down to mar the beautiful finish of your typewriter because the linespacing mechanism is so ingeniously designed that as the finger pad moves to the right, it also rises for greater clearance with the top of the machine.

Page End Gage

Here at last for the first time on portable typewriters is a dependable means for predetermining the exact bottom page margin desired. With this page end gage, bottom margins on multiple pages of a letter, manuscript, thesis, etc., can be held uniform on each sheet.

It is a simple device to use. You need only remember that the green markings are for the length of paper being used and the red markings to gage the predetermined bottom margin.

If you are using paper 11 inches long turn the platen roller until the green numeral 11 is in line with the top edge of the SET Indicator. Now insert the paper in the usual manner and proceed with the typing.

Green markings without numerals are for fractional inch paper lengths such as, 8½, 9½, 10½ inches and so on.

This paper gage has but four numerical paper length indexes (green numerals 8, 9, 10 and 11). For paper shorter than 8 inches, turn the platen roller so the numeral 8 is in line with the SET Indicator and then before inserting the paper turn the right hand platen knob clockwise one green mark, whether it has a green numeral or not, for each half inch of paper less than the 8 inch length. For example: the green mark between 8 and 11 is for paper 7½ inches long. Should the paper be greater than 11 inches long, turn the right hand platen knob to the green 11 and then turn it counter-clockwise one mark for each half inch of paper greater than 11 inches. For 14 inch paper the green mark having numeral 10 will be in line with the SET Indicator.

Let us assume you have decided upon a 1 inch bottom margin. As the bottom of the sheet is approached glance occasionally at the red markings as you linespace. When the red numeral 1 comes up in line with the top edge of the TO END Indicator you have a 1 inch bottom margin. The red markings (dashes) without numerals are for fractional margins.

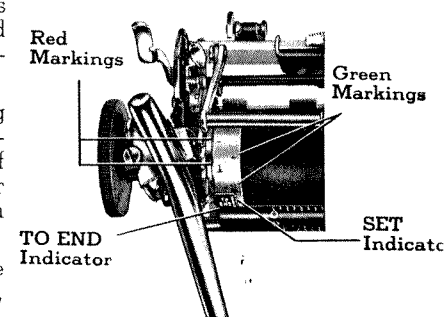

CHART

This chart demonstrates a few Smith-Corona Page Gage applications.

| Paper Lengths | Gage Bottom Margins the Same on All Paper Lengths | | |
|---------------|---|-------------------------------|------------------------------|
| Length Inches | Green Mark on SET Indicator | Various Bottom Margins—Inches | Red Mark on TO END Indicator |
| 8 | 8 | ½ inch | First after 1 |
| 7 | 11 | 1 inch | 1 |
| 5½ | Between 9 & 10 | 1½ inches | First after 2 |
| 10 | 10 | 2 inches | 2 |
| 13 | 9 | 2½ inches | Second after 1 |

The Line Retainer (Fig. 10)

This feature, on Smith-Corona Silent-Super, Silent and Sterling models only, is a great asset when you want to vary your linespacing a bit to use a figure as a subscript (H₂O) or exponent (60°) and then return to exactly the original spacing. To do this move the line retainer down. When ready to return to original spacing flip the lever up. This feature is also useful for

interlining, i.e., "Opportunities in the field/are being neglected."

The Variable Linespace (Fig. 10)

The Variable Linespace: as the name implies, permits rolling the paper up or down for any conceivable spacing to suit your whim or for typing exactly on the lines of ruled paper or lines of a printed form. To variably linespace pull out the variable knob until it clicks. Since it is impossible to set the variable of your Smith-Corona in a neutral position, where it will neither be way out on linespacing, there is no need to fear that the mechanism can be damaged. Try this—pull the

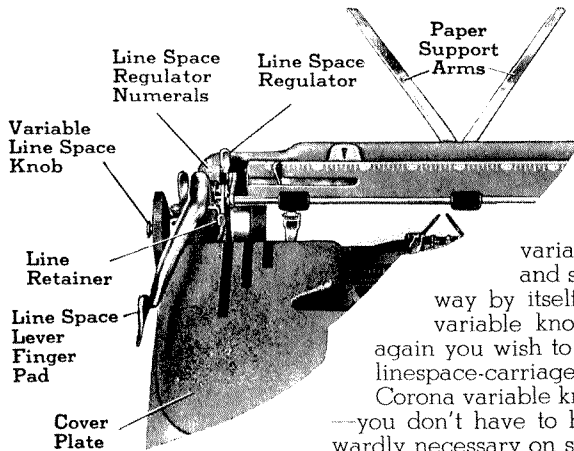

Figure 10

variable knob slowly to half way and see it pop out the rest of the way by itself. Don't forget to push the variable knob back into normal when again you wish to linespace by means of the linespace-carriage return lever. The Smith-Corona variable knob stays out on "variable"—you don't have to hold it there as is so awkwardly necessary on some machines.

Retractable Paper Support Arms (Fig. 10)

(Regular Equipment on Smith-Corona Silent-Super, Silent and Sterling Models. Not on the Clipper)

There they are, mounted behind the paper table, with just their tips visible when folded, thus preserving the trim, streamline appearance for which Smith-Corona is noted. Pull up on one of the support arms and the other comes up also. They are geared together and have a unique spring mounting that holds them folded or erect so they will not rattle or drop down unexpectedly. The purpose of these arms is to support the paper so that you can read what you have typed. At the same time they prevent the paper from drooping over onto the desk or table.

Line Indicator and Printing Point (Fig. 11)

When typed copy must go back into the machine for corrections or additional typing, these items of equipment provide for paper reinsertion in register with the original typing.

Pull out the variable linespace knob (See Fig. 10) and roll the paper so that the bottom of an originally typed line is even with the wings of the line indicator.

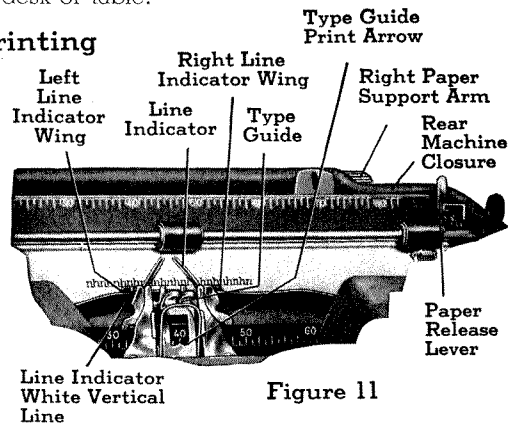

Figure 11

The Keyboard Operational Keys (Fig. 8)

The shift, shift lock, tabulator, margin release and backspace are all of the same pleasing, durable plastic construction. You have already been told the primary uses of the margin release and backspace keys. Later we will cover the tabulator.

Want a capital letter? Depress one of the shift keys, hold it and tap the desired letter. Some keys have more than one character. Any of these upper or secondary characters print when either shift key is down. Should you want to type a number of capitals consecutively, press the shift lock key until it catches. Presto, the whole type segment unit is locked down in capital position but may be instantly released by tapping either the right or left shift key. Capital shifting on Smith-Corona was made for operating with the little fingers. We use the name "Floating Shift" because the shifting action is so light that the typebar segment or "basket" veritably floats on frictionless ball bearings while the carriage remains firmly anchored on its vibrationless base. Most typewriter manufacturers have finally adopted the segment shift principle which Smith-Corona has used since 1904.

Space Bar (Fig. 8)

The space bar is a very important part of your keyboard. But first notice how beautifully it blends into the general contours of the machine instead of sticking out like a necessary evil. Here again you have the latest plastic engineering. Do not forget the all important stroke on the space bar for that space so necessary between each word.

Manual Ribbon Reverse Lever (Fig. 8)

The manual ribbon reverse is located on the left side of the keyboard. Since the feeding and reversing of the ribbon, back and forth from left to right, is entirely automatic, you will probably seldom use this little lever until it is time to replace the ribbon.

Ribbon Color Lever (Fig. 8)

This is located on the right side of the keyboard and may be moved to three positions, indicated by colored dots. When the lever is opposite the blue dot the type strikes the upper half of the ribbon and when opposite the red dot the type strikes the lower or red half of the ribbon. When you move the ribbon color lever to neutral or opposite the white dot the ribbon will not raise to let the type strike it. This is called the stencil position. Smith-Corona typewriters do a wonderful job in cutting mimeograph stencils.

Typing is easy, so the experts say, and certainly there are hundreds of thousands of Smith-Corona users who have never had any instruction in typing. Nevertheless you will derive more satisfaction from your machine and save a great deal of time if you will master the rudiments of touch typing which you can do easily by following the condensed instructions on the touch typing card which came with your machine.

ber of spaces before the end regardless of how long or short you are making the lines. This signal provides a means of gaging your typing, as the end of the line approaches, so as to end short words or a full syllable, on or just before the margin line. A neat, uniform right hand margin is the mark of an expert.

The linelock locks exactly on the space where you have set the right marginal stop. Therefore, if you set the right margin at "70" the last space you can type will be "69". Your reliable linelock prevents the next key going down to print unless, of course, you tap the margin release key. The dual action linelock is still on duty. If you release the right margin and continue to the extreme end of the line the linelock locks again at the end so that you won't, in haste, produce unsightly type strikes on top of each other.

Here is Your Smith-Corona Keyboard



Figure 8

It is the latest thing in key top design for the greatest functional comfort with the least fatigue. The key tops are concaved for Finger-Fit and modified "tear drop" shaped for Finger-Form. They are of molded plastic and the characters are wear proof, infused flush with the top surface so they cannot fill with dirt. They will give you a lifetime of legibility.

In addition to these marvelous keys you have the famous Smith-Corona Piano Key action. It is this exclusive action that, like a piano, causes the keys to go down in the same arc as your typing fingers. Hence your fingers are in the same contact position on the keys at the end of the stroke as at the beginning. No slippage on the keys that can be so tiring and sometimes cause broken finger nails.

While on the subject of keys and action, lift up the cover plate as in Figs. 9 or 14, and notice, when you try to raise them, that the typebars are locked down until a key is depressed. This is your guarantee that bars will not bounce to collide and destroy typing rhythm as in ordinary portables. Locking typebars is another Smith-Corona exclusive of which you can be justly proud.

Release the paper and move it sideways so that the white vertical lines in the wings of the indicator register exactly opposite the centers of typed characters. While the paper is still released be sure it is straight by accurately lining up an originally typed line with BOTH wings of the line indicator.

See that the paper release lever and variable linespace knob are back in normal position and then you are ready to proceed in register with the original copy.

You can predetermine where a type is going to strike because the print arrow of the type guide points to the "Printing Point".

The Key Set Tabulator

The Silent-Super Model gives you a famous Smith-Corona Portable with the most ruggedly constructed KEY SET Tabulator in portable history. You can be sure that the Smith-Corona Key Set Tabulator, regular equipment on the Silent-Super Model only, is absolutely dependable.

Tabulating Set-Up

1. Move the carriage to the first selected tabulating location.
2. Press down the SET key to set a tabulator stop at selected space.
3. Following the first 2 steps, set as many stops as needed.
4. Now tabulate by pressing down the Tab key.

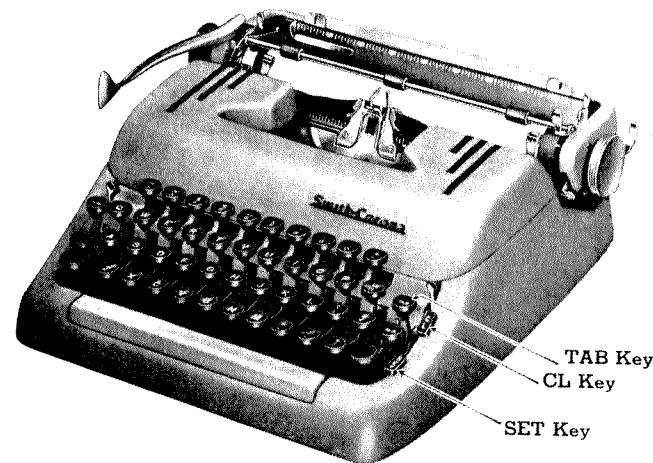

Clearing The Tabulator Set-Up

1. If you wish to clear only one tabulator stop, move the carriage (tabulate) to that location and press the CL (Clear) key.
2. Continue to thus clear as many individual stops as you wish.
3. To clear the whole tabulating set-up at once; move the carriage to the extreme right, hold down the CL key and depress the Tab key.